

INSTALLATION INSTRUCTIONS

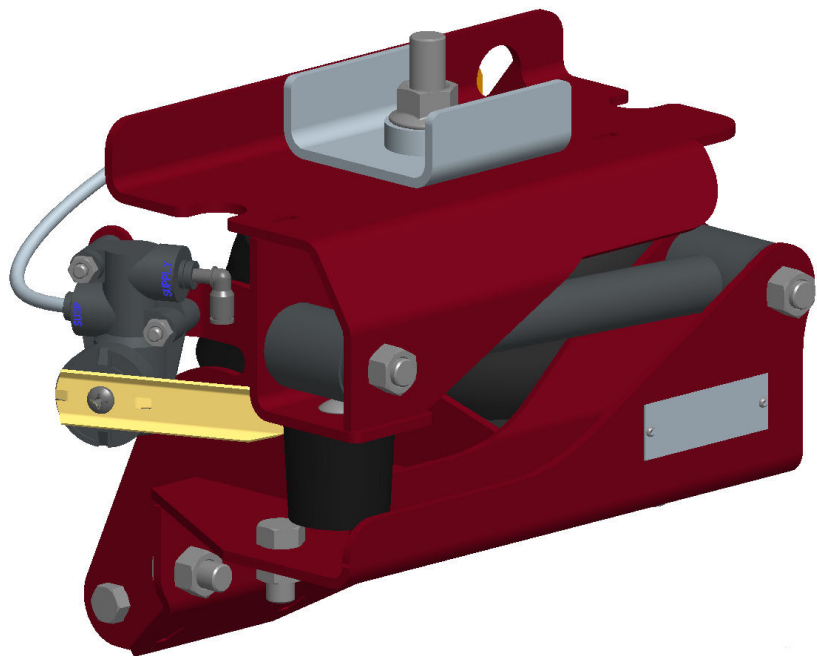

PBC335 (AFTM) (2840G000)



The **CABMATE MODEL PBC335 (AFTM)** fits most Peterbilt 335 Conventionals. It replaces the original cab support, Peterbilt Part No. 20-15951, 20-13321, or 20-00621. **Dual exhaust requires ordering an additional exhaust bracket, Link Part No. 2899-A000. This unit will not fit trucks equipped with Able Body Sleepers.**

*Link mfg. Ltd.
223 15th St. N.E.
Sioux Center, IA USA
51250-2120*

*(712) 722-4874
Fax (712) 722-4876*

**QUESTIONS?
CALL CUSTOMER
SERVICE
1-800-222-6283**

UNIT WEIGHT: 23.8 LB.

NET WEIGHT ADDED: 9.4 LB.

090414
38400004

CABMATE[®] MODEL PBC335 (AFTM)

Review the Parts List on page 3 to become familiar with the different components of the CABMATE.

IMPORTANT: Due to many chassis variables caused by installation of special equipment or options, the fit of the CABMATE PBC335 (AFTM) may be affected and should be evaluated before beginning installation.

IMPORTANT: Installation of the CABMATE system will allow the cab to move freely. Before starting installation, check clearances between the cab and any objects the cab may contact when it moves (1 1/2 inches of clearance should be sufficient). The clearance of components that are affected by cab movement, such as exhaust and radiator systems, must also be evaluated.

- A. Remove the stock mount bolts from the bottom of the original rear cab mount. Securely prop up the cab and remove all stock mount parts.
- B. Slide the CABMATE between the cab and the crossmember from underneath the cab. Loosely fasten the Unit Bottom to the crossmember using the eight 1/2" mount bolts (Item Nos. 9 and 18 from parts list on page 3).

HINT: It may be easier to first drop the cross member, mount the Cabmate to the cross member, and then reinstall the cross member.

- C. Lower the cab until it touches the top of the CABMATE. With the Unit Top and the Unit Bottom aligned, fasten the Unit Top to the cab using the 5/8" mount bolt (Item Nos. 10 and 27 from parts list on page 3). **SECURELY TIGHTEN ALL FASTENERS.**
- D. See page 2 for plumbing instructions and height adjustments.
- E. **IMPORTANT:** After plumbing and height control adjustments are completed, temporarily adjust the CABMATE to its maximum upward position. There must be a minimum of 1/4" gap between the cab and the hood. Adjust the hood hinge forward as necessary (Fig. 3).

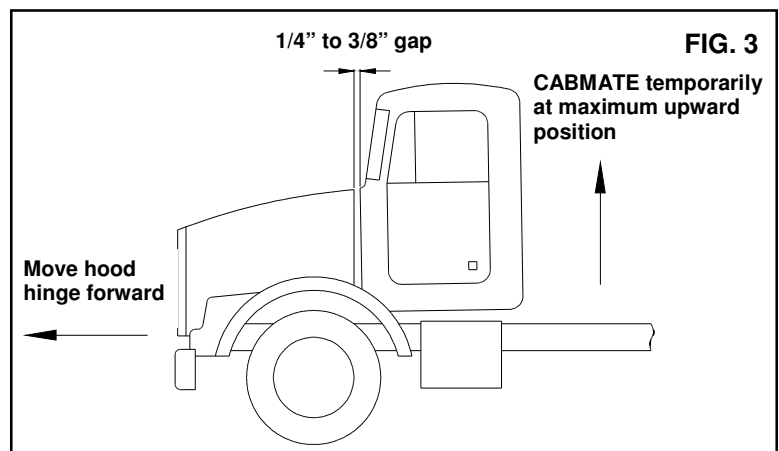
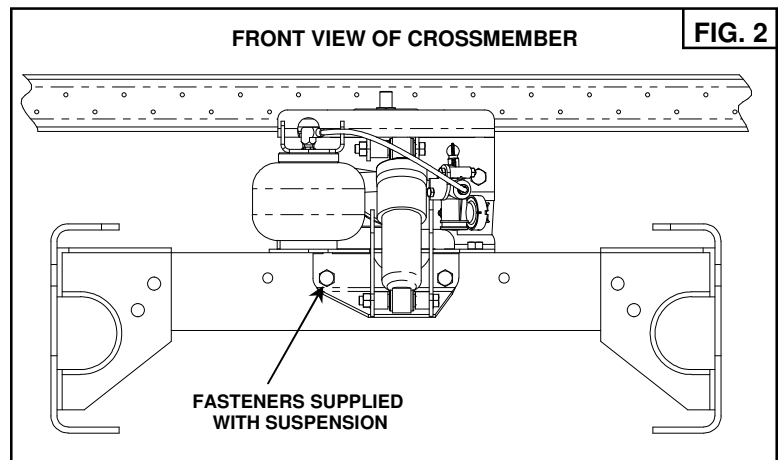
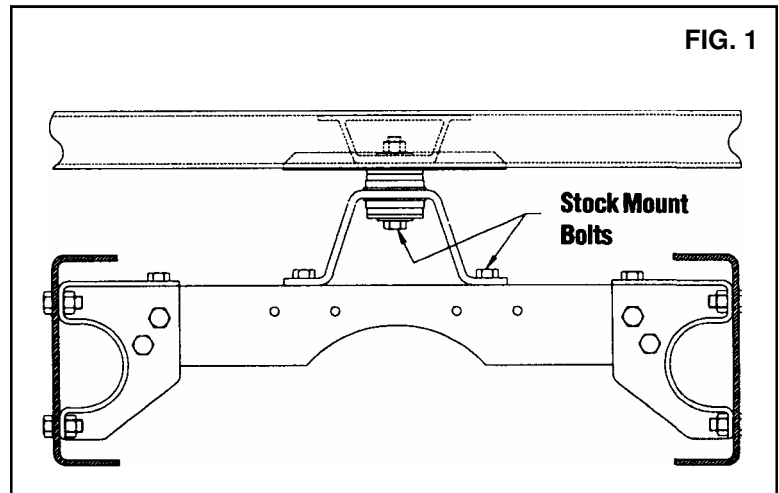

PLUMBING INSTRUCTIONS

WARNING: FOR SAFTY PURPOSES THE CABMATE MUST BE SUPPLIED FROM A PRESSURE PROTECTED CIRCUIT. IN THE EVENT OF AN AIR LEAK IN THE CAB SUSPENSION, FAILURE TO PROVIDE A PRESSURE PROTECTED CIRCUIT MAY CAUSE LOSS OF AIR PRESSURE TO VITAL SYSTEMS ON THE VEHICLE.

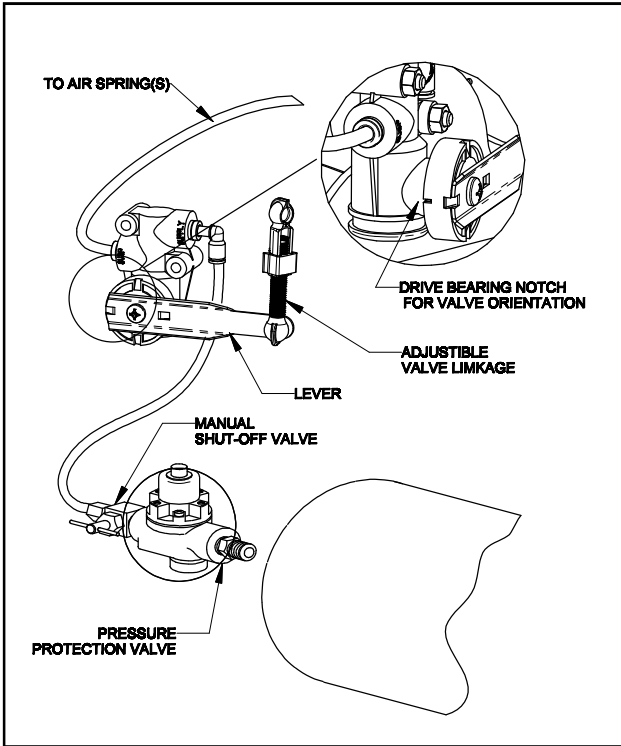

WARNING: LOSS OR APPLICATION OF AIR PRESSURE TO CABMATE WILL CAUSE SUDDEN MOVEMENT OF THE CAB. PRIOR TO INSTALLING OR PERFORMING MAINTENANCE, BLOCK UP THE CABMATE TO PREVENT THE POSSIBILITY OF INJURY.

WARNING: CONNECT THE CABMATE DIRECTLY TO THE MAIN AIR TANK. YOU WILL NEED AN AIR PRESSURE PROTECTION VALVE IN THE LINE. (INCLUDED IN THE PRESSUREPROTECTION KIT. LINK MFG. PART NO. 1350-0000). DO NOT USE AN AIR PRESSURE REGULATOR!

A. With the tank at 0 p.s.i., remove the existing plug or fitting from the desired port.

B. Apply joint compound to the fittings and install the pressure protection kit. **DO NOT USE TEFLON TAPE.** Be sure that the arrows on the valve are pointing in the direction of air flow and the vent hole is pointed down. **NOTE:** Additional fittings/reducers may be required to attach the hex nipple to the main air tank.

C. Run the 1/4" airline from the shut-off valve to the CABMATE. Be sure that the airline has enough clearance so that there are no pinch points that may restrict or cut the airline. Secure the airline using the cable ties supplied by Link Mfg.

D. Tighten all plumbing fittings. Then, with the system at operating pressure (90 to 110 p.s.i.), open the Manual Shut-off Valve to supply air to the CABMATE. Check the system for air leaks.

E. Check for proper operation of the height control valve. Disconnect the valve linkage from the lever. Push the lever down 45°, air should flow into the air spring (s). Return the lever to the neutral position. Push the lever up 45°, air should exhaust from the air spring(s). Return the lever to the neutral position; no air should flow. Reconnect the valve linkage to the lever.

HEIGHT ADJUSTMENTS

Measure the design height of the air spring(s). The height should be 4.90" inches ± 1/16. To change the height, disconnect one end of the valve linkage and adjust accordingly. Tighten the lock nuts on the valve linkage.

MAINTENANCE

CABMATES need no lubrication and little maintenance. The following components should be checked at the time the truck is being serviced. However, immediate corrective action should be taken if a serious malfunction occurs.

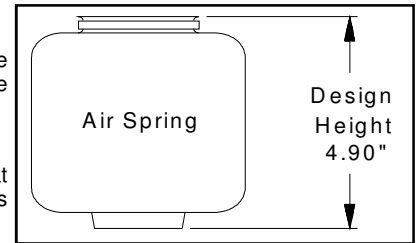

COMPONENT	POSSIBLE PROBLEM	CORRECTIVE ACTION	TORQUE
Airlines	Air leaks	Replace airline	Compression Nut Hand Tight + 1 Turn
Fittings	Air leaks	Remove fitting and apply fresh joint compound. Reinstall fitting, but Do Not Overtighten. Do not use teflon tape.	Threaded into: Metal Plastic 15 Hand Tight Ft. Lbs. + 1 Turn
Air Springs	A. Improper height B. Air leakage	A. Adjust valve linkage to maintain proper air spring height. B. Replace air spring.	Size Metal Plastic 3/8 25 Ft. Lbs 04 Ft. Lbs 1/2 28 Ft. Lbs 10 Ft. Lbs 3/4 30 Ft. Lbs 10 Ft. Lbs
Height Control Valve	Air spring(s) will not inflate when wheight is added to the cab; OR Air spring(s) will not deflate when wheight is removed from the cab.	A. Inspect valve to insure drive bearing notch is located on "SUSP" port side of valve. If not, loosen lever screw (but do not remove completely) and pull lever loose from drive bearing, rotate drive bearing until the bearing notch is in the correct position and resecure lever by tightening lever screw. B. Replace Valve	1/4 Mount Fasteners 10 Ft. Lbs. Bearing Screw 40-50 InLbs.
Shock Absorber	Insufficient dampening effect	Replace shocks	45 Ft. Lbs.
Lateral Control Rod	A. Loose nuts on lateral control rod bolts B. Worn bushings.	A. Tighten securely to clamp the inner sleeve. B. Replace lateral control rod.	40 Ft. Lbs.

IMPORTANT: Periodically check the tightness of all fasteners.

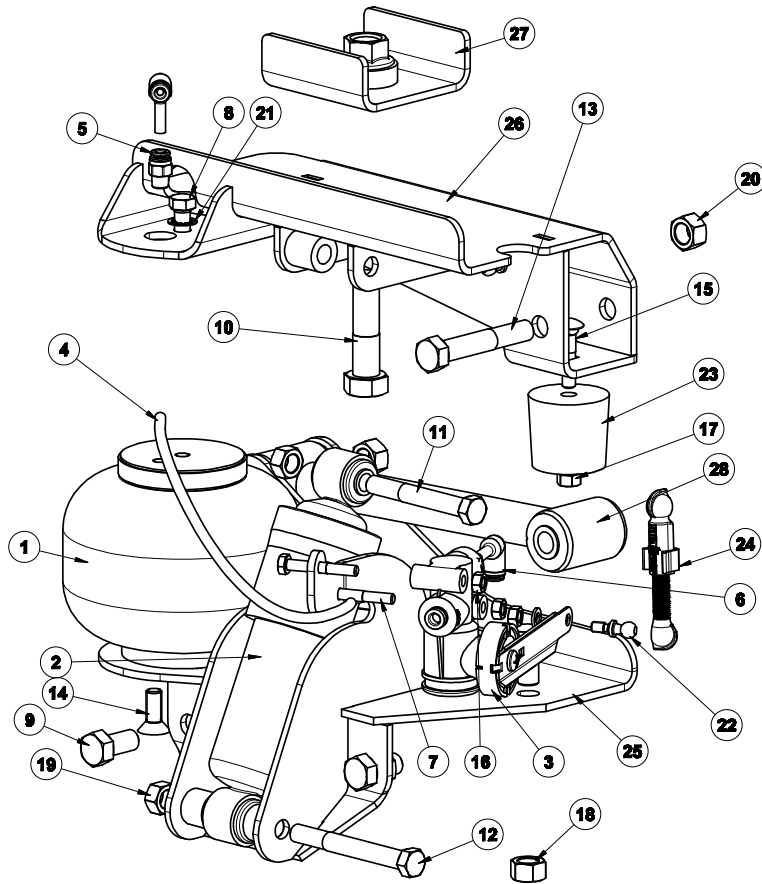

CABMATE® MODEL PBC335 PARTS LIST

ITEM #	PART #	DESCRIPTION	QTY.
1	1102P078	SPRING-AIR	1
2	1202P055	SHOCK ABSORBER	1
3	1350-0102	ASSEMBLY-HEIGHT CONTROL VALVE	1
4	1302-0090	AIRLINE-NYLON, .250 O.D., BULK	1.00 Ft.
5	13025201	CONNECTOR, 1/4 TB 1/8 M-NPT	1
6	1302-5499	ELBOW-PLUG-IN, 1/4"	2
7	1401-0814	1/4 X 1 3/4 UNC HEX CAP SCR (GR 5)	2
8	1401-1205	3/8 X 5/8 UNC HEX CAP SCR (GR 5)	1
9	1401-1608	1/2 X 1 UNC HEX CAP SCR (GR 5)	4
10	1401-2020	5/8 X 2 1/2 UNC HEX CAP SCR (GR 5)	1
11	1403-1426	7/16 X 3 1/4 UNF HEX CAP SCR (GR 5)	1
12	1403-1430	7/16 X 3 3/4 UNF HEX CAP SCR (GR 5)	1
13	1404-1624	1/2 X 3 UNF HEX CAP SCR (GR 8)	2
14	1417-1208	3/8 X 1 UNC SOC FLAT CSK HD CAP SCREW	1
15	1435-1012	5/16 X 1 1/2 UNC RND HD SQ NK BOLT (GRADE 5)	1
16	1476-0800	1/4 UNC HEX CTR LOCK NUT (GR B)	2
17	1476-1000	5/16 UNC HEX CTR LOCK NUT (GR B)	1
18	1476-1600	1/2 UNC HEX CTR LOCK NUT (GR B)	4
19	1477-1405	7/16 UNF HEX TOP LOCK NUT (GR B)	2
20	1477-1601	1/2 UNF HEX TOP LOCK NUT (GR C)	2
21	14851205	3/8 INT TOOTH LOCK WASHER, ZINC	1
22	2991-0026	KIT-PIVOT BALL	2
23	1500-0070	BUMPER-JOUNCE, 1.75	1
24	29910050	LINKAGE-VALVE	1
25	28400100	BRACKET-MOUNT, PBC335 CROSSMEMBER	1
26	28400101	BRACKET-MOUNT, PBC335 CAB	1
	28400105	PLATE-MOUNT, FASTENER	1
28	29934003	LATERAL CONTROL ROD	1
-	1350-0000	KIT-PROTECTION, PRESSURE	1